

DECLARATION OF PERFORMANCE

No. **0764-CPR-0250 – UK - vs01**

1. Unique identification code of the product-type:

ROCKPANEL Lines²

8 mm and 10 mm tongue and groove panels finish Colours/Rockclad

2. Intended use / es:

Internal and external wall and ceiling finishes

3. Manufacturer:

ROCKWOOL B.V. / ROCKPANEL Group
Konstruktieweg 2
NL-6045 JD Roermond
Tel. +31 475 353 000
Fax +31 475 353 550

4. System or systems of AVCP (assessment and verification of constancy of performance of the construction product) as set out in Annex V (amended by : OJ L 157, 27.5.2014, p. 76-79)

System 1

5. European Assessment Document:

EAD 090001-00-0404 for Prefabricated compressed mineral wool boards with organic or inorganic finish and with specified fastening system, edition May 2015.

European Technical Assessment: ETA-13/0204 of 2015-11-10

Technical Assessment Body:

ETA-Danmark A/S
Göteborg Plads 1, DK-2150 Nordhavn
Tel. +45 72 24 59 00
Fax +45 72 24 59 04
Internet www.etadanmark.dk

Notified Body:

Materialprüfanstalt für das Bauwesen
Nienburger Strasse 3, D-30167 Hannover
Notified Body 0764
Tel. +49 511 762 3104
Fax +49 511 762 4001
Internet www.mpa-bau.de/

and issued:

Certificate of Constancy of performance No. 0764 - CPR – 0250

6. Characteristics of the product

ROCKPANEL Lines² tongue and groove panels, thicknesses 8 and 10 mm, finish Colours/Rockclad is made from prefabricated compressed rock wool panels with thermo-hardening synthetic binders. The tongue and groove panels are fastened to timber subframes. Fastening of the 8 mm panels to the timber subframe is carried out with corrosion resistant fixing clips with screws.

Fastening of the 10 mm panels to the timber subframe is carried out with corrosion resistant nails or screws.

The ROCKPANEL Lines², 8 mm and 10 mm tongue and groove panels, are surface treated with a two-layer water-borne polymer emulsion paint on one side, in a range of colours.

The physical properties of **ROCKPANEL Lines²**, 8 mm and 10 mm, are indicated below:

- thickness	8 ± 0.5 mm / 10 ± 0.5 mm	
- length, max	3050 mm	
- panel width > <i>working width</i>	S 8 : 164 > 151-156 [a]	S 10 : 164 > 146
	XL 8 : 295 > 282-287 [a]	XL 10 : 295 > 277
	<i>[a] : min-max working width</i>	
- panel width tolerances	nominal +1/-1 mm	
- density	nominal 1050 ± 150 kg/m ³	
- bending strength	length and width $f_{05} \geq 27$ N/mm ²	
- Modulus of Elasticity	4015 N/mm ²	
- Thermal conductivity	0.37 W/(m.K)	

The mounting details and fixing dimensions of **ROCKPANEL Lines²**, 8 mm and 10 mm, are indicated in Figure 1.

Figure 1. Mounting details and fixing dimensions ROCKPANEL Lines²

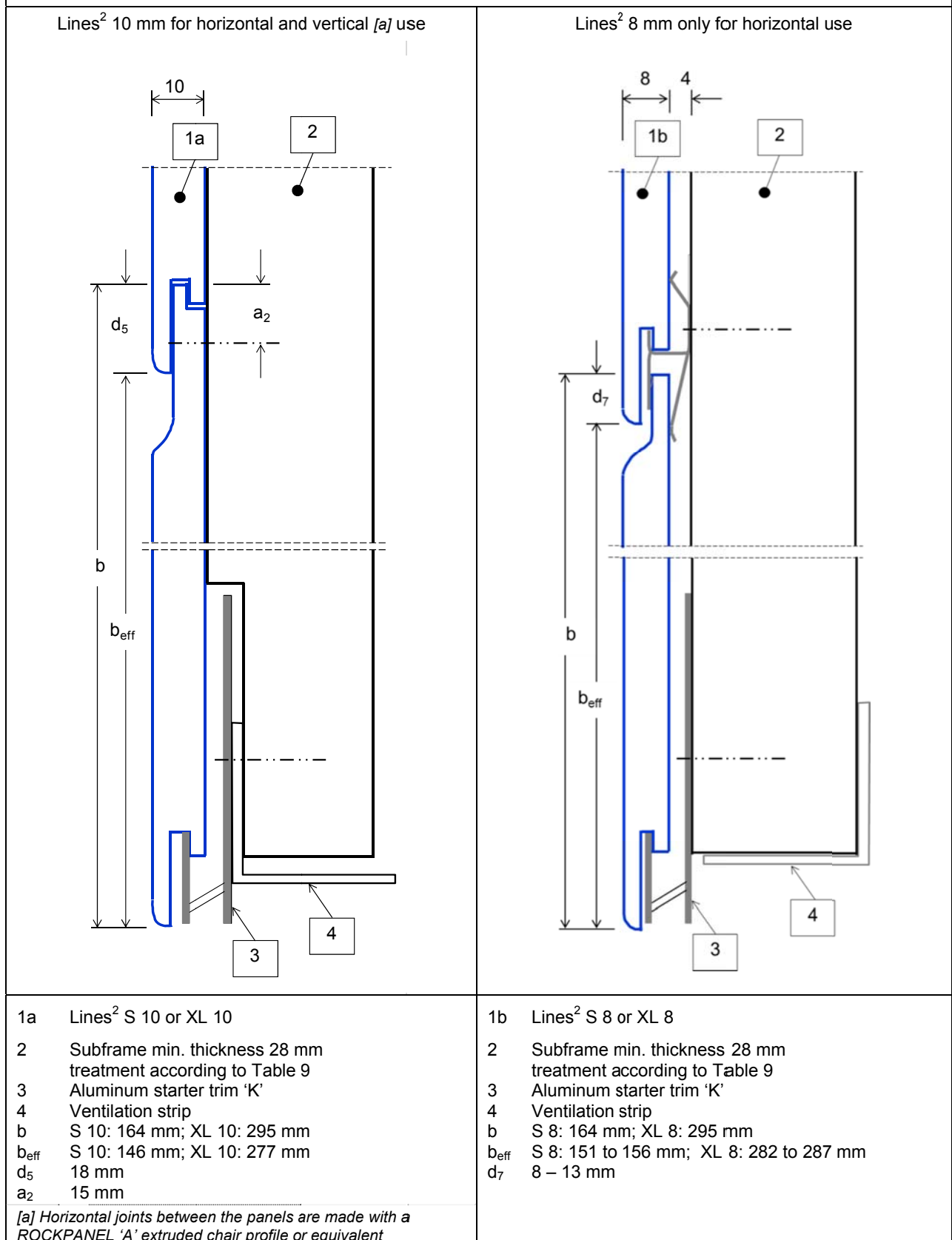

Clause 7 contains the performances of ROCKPANEL Lines² 8 mm and 10 mm tongue and groove panels.

7. Declared performance

The panels have been classified in accordance with EN 13501-1 with the following parameters:

Essential characteristics	Performance			Harmonised technical specification
	Table 1. Euroclass classification of different constructions with ROCKPANEL Lines ² panels			
Basic Requirements for construction works BR2 - Safety in case of fire	Fixing method	Ventilated or non-ventilated	Vertical wooden subframe – Lines ² in the thicknesses	
	Mechanically fixed	Ventilated	8 mm [a]	10 mm
			8 mm	
			B-s2,d0	C-s2,d0
				ETA-13/0204 issued 2015-11-10 EN 13501-1:2007

[a] With the use of 8 mm ROCKPANEL strips on the vertical battens; width of the strip 15 mm at both sides wider than the batten

Field of application

The following field of application applies.

Euroclass classification

The classification mentioned in Table 1 is valid for the following end use conditions:

- Mounting
 - Mechanically fixed to a wooden subframe
 - The boards are backed with min. 40 mm mineral wool insulation density 30-70 kg/m³ according to EN 13162 with a cavity between the back of the board and the insulation
- Substrates:
 - Concrete walls, masonry walls
- Insulation:
 - The panels are backed with min. 40 mm mineral wool insulation with density 30-70 kg/m³ according to EN 13162 between the battens and min. 50 mm with density 30-70 kg/m³ according to EN 13162 kg/m³ behind the battens without air gap
 - Results are also valid for all greater thickness of mineral wool insulation layer with the same density and the same or better reaction to fire classification
 - The test result of a test with mineral wool insulation shall be valid, without test, for the same type of panel used without insulation, if the substrate chosen according to EN 13238 is made of panel with Euro-class A1 or A2 (e.g. fibres-cement panel).
- Subframe:
 - Vertical softwood battens without fire retardant treatment, thickness minimum 28 mm
 - Test results are also valid for the same type of panel with aluminum or steel frame
 - Test results are also valid for the same type of panel with vertical LVL battens, without fire retardant treatment, thickness minimum 27 mm
- Fixings:
 - Results are also valid with higher density of the fixing devices
 - Test results are also valid for the same type of panel fixed by rivets made of the same material of screws and vice versa
- Cavity:
 - Unfilled
 - The depth of the cavity is minimum 28 mm
 - Test results are also valid for other higher thickness of air space between the back of the board and the insulation behind the subframe
- Joints:
 - Horizontal applications Lines² 8 mm and 10 mm
 - Vertical joints are open without gasket backing or ROCKPANEL strip backing as described in table 4; the horizontal seams are automatically covered by the overlaid board.
 - Vertical application of Lines² 10 mm
 - an open horizontal joint is also valid for the same type of panel used in applications with horizontal joints closed by steel or aluminum profiles

The classification is also valid for the following product parameters:

- Thickness:
 - Nominal 8 mm or nominal 10 mm, individual tolerances ± 0.5 mm
- Density:
 - Nominal 1050 kg/m³, individual tolerances ± 150 kg/m³

Essential characteristics	Table 2 - Performance - Water vapour permeability and water permeability		Harmonised technical specification
	Property	Declared values	
BR3 – Hygiene, health and environment	Water vapour permeability	s_d declared ≤ 1.8 m at 23°C and 85% RH The designer shall consider the relevant needs for ventilation, heating and insulation to minimise condensation in service.	ETA-13/0204 issued 2015-11-10 EN ISO 12572 test condition B
	Water permeability	NPD [a]	ETA-13/0204 issued 2015-11-10

[a] The cladding kit shall be designed and installed so that water which penetrates in the air space or condensation water shall be drained out of the installed kit without accumulation or moisture damage or leakage into the substrate or the wall cladding kit

Essential characteristics	Table 3 - Performance - Release of dangerous substances		Harmonised technical specification
	Property	Product specification	
BR3 – Hygiene, health and environment	Influence on air quality and Release of dangerous substances to soil and water	Use category: Outdoor S/M2 The kit does not contain/release dangerous substances specified in TR 034, dated April 2013*), except Formaldehyde concentration 0.0105 mg/ m ³ . Formaldehyde class E1 The used fibres are not potential carcinogenic No biocides are used in the ROCKPANEL boards No flame retardant is used in the boards No cadmium is used in the boards.	ETA-13/0204 issued 2015-11-10

*) In addition to the specific clauses relating to dangerous substances contained in this European technical Assessment, there may be other requirements applicable to the products falling within its scope (e.g. transposed European legislation and national laws, regulations and administrative provisions). In order to meet the provisions of the Construction Products Regulation, these requirements need also to be complied with, when and where they apply.

Essential characteristic	Table 4a - Performance - Design value of the axial load for mechanical fixing Lines² 10 mm [f]					Harmonised technical specification			
	For service class 2 (see 'Note') and load-duration class 'Instantaneous' [c] For hole diameters fixings see Table 5; For positions fixings see Table 6			$X_d = X_k / \gamma_M$ in N				Table in ETA	
	Property	Lines ² 10 mm	Span in mm [b]		Middle / Corner [g]				
BR4 – Safety in use	Design value of the axial load $X_d = X_k / \gamma_M$	screw fixing [a][e] single [g] screw on intermediate battens	600	b panel	146	204 / 85	204 / 85	6 [c]	ETA-13/0204 issued 2015-11-10 EN 14592:2008+A1:2012 (E)
				277	204 / 116	204 / 116			
		screw fixing [a][e] double [g] screw on intermediate battens	600	146	296 / 85	296 / 85	7 [c]		
				277	357 / 116	357 / 116			
		nail fixing (27 mm) [e] single [g] nail on intermediate battens	600	146	130 / 121	156 / 121	8 [c]		
				277	130 / 130	156 / 149			
nail fixing (27 mm) [e] double [g] nail on intermediate battens	600	146	261 / 121	281 / 121	9 [c]				
		277	261 / 130	311 / 149					
[a] with $\alpha \geq 30^\circ$: α is the angle between the screw axis and the grain direction				[d] Strength class BS EN 338					
[b] see Table 5				[e] for specifications fixings see Table 8a					
[c] $k_{mod} = 1.10$ in accordance with Table 3.1 – 'Values of k_{mod} ' BS EN 1995-1-1:2004+A1:2008; For 'service class' 2 [NA to BS EN 1995-1-1:2004+A1:2008 Table NA.2 "External uses where member is protected from direct wetting"] and 'load-duration class' 'Instantaneous' [Table NA.1 NA to BS EN 1995-1-1:2004+A1:2008]				Note (according to BS EN 1995-1-1:2004+A1:2008 §2.3.1.3 (3)P) : Service class 2 is characterised by a moisture content in the materials corresponding to a temperature of 20°C and the relative humidity of the surrounding air only exceeding 85 % for a few weeks per year. In service class 2 the average moisture content in most softwoods will not exceed 20 %.					
[f] for preservative treatment subframes see Table 9				[g] see Table 5 and 6					

Essential characteristic	Table 4b - Performance - Design value of the axial load for mechanical fixing Lines² 8 mm [f]									Harmonised technical specification	
	For the combination Lines² XL 8 , clip and round-top screw 3,5x25, with $\alpha \geq 30^\circ$ [a]; For service class 2 (see 'Note') and load-duration class ' Instantaneous ' [c] For positions fixings see table 6a/6b										
	Property	Span in mm [b]		$X_d = X_k / \gamma_M$ (in N) for C18 / C24 [d]							Table in ETA
	a	b	A	B	C	D	E	F			
BR4 – Safety in use	Design value of the axial load	151 - 156	600	53	84	39	69	113	60	10 [c]	ETA-13/0204 issued 2015-11-10
	$X_d = X_k / \gamma_M$	282 – 287	600	53	92	39	69	113	60	11 [c]	
[a] with $\alpha \geq 30^\circ$: α is the angle between the screw axis and the grain direction						[d] Strength class BS EN 338					
[b] see Table 5						[e] for specifications fixings see Table 8					
[c] $k_{mod} = 1.10$ in accordance with Table 3.1 – 'Values of k_{mod} ' BS EN 1995-1-1:2004+A1:2008; For 'service class' 2 [NA to BS EN 1995-1-1:2004+A1:2008 Table NA.2 "External uses where member is protected from direct wetting"] and 'load-duration class' ' Instantaneous ' [Table NA.1 NA to BS EN 1995-1-1:2004+A1:2008]						Note (according to BS EN 1995-1-1:2004+A1:2008 §2.3.1.3 (3)P): Service class 2 is characterised by a moisture content in the materials corresponding to a temperature of 20°C and the relative humidity of the surrounding air only exceeding 85 % for a few weeks per year. In service class 2 the average moisture content in most softwoods will not exceed 20 %.					
[f] for preservative treatment subframes see Table 9											

Essential characteristic	Table 5 – Performance fixings according to table 4a and 4b with the required edge distances, maximum distances and fixing method						Harmonised technical specification		
	CLIP fixing locations ROCKPANEL Lines ² 8 mm type S 8 and XL 8			Nail / screw fixing - hole diameters mm for Lines ² 10 mm type S 10 and XL 10					
BR4 – Safety in use							ETA-13/0204 issued 2015-11-10 Table 10, 11 and 13		
	Fixing type [a]	a ₁ mm	b max mm	Working width mm		Diameter hole mm			
				Type	a _{min}	a _{max}		M – middle of the panel	
	clip	≥ 20	600	S	151	156		Other locations	
			XL	282	287	nail	a ₁ mm	l _e mm	l _m max mm
						screw	≥ 15	≤ 600	3050
							≥ 15	≤ 600	3050

[a] for specifications fixings see Table 8
[b] The consequence of this diameter is that under certain circumstances a tension perpendicular to the shafts of the fixings in the fixing locations can occur.

Essential characteristic	Table 6 – Performance fixings according to Table 4 and 5 with the required Fixing locations		Harmonised technical specification
	Lines ² 10 mm type S 10 and XL 10 - Nail / screw fixing - hole diameters mm		
BR4 – Safety in use			ETA-13/0204 issued 2015-11-10 Table 6, 7, 8, 9 and 12
	$a_1 \geq 15 \text{ mm}$ $a_2 = 15 \text{ mm}$ $a_3 \geq 20 \text{ mm}$	C: corner fixing M: Middle fixing	

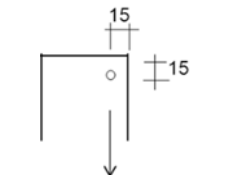
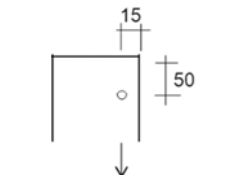
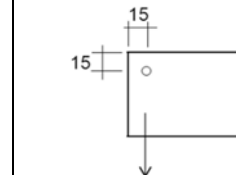
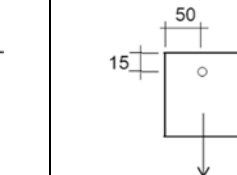
Essential characteristic	Table 7a – Performance shear strength mechanical fixings Lines² 10 mm					Harmonised technical specification	
	Characteristic shear strength Average values						
BR4 – Safety in use	Fixing						ETA-13/0204 issued 2015-11-10
		Nail 2.1/2.3x27	795 N	914 N	838 N	866 N	
		Screw 3.5x30	822 N	1083 N	1124 N	1074 N	

Essential characteristic	Table 7b – Performance shear strength mechanical fixings Lines² 8 mm	Harmonised technical specification
BR4 – Safety in use	Deformation of the clip due to three times the own weight of type XL: < 0,1 mm	ETA-13/0204 issued 2015-11-10

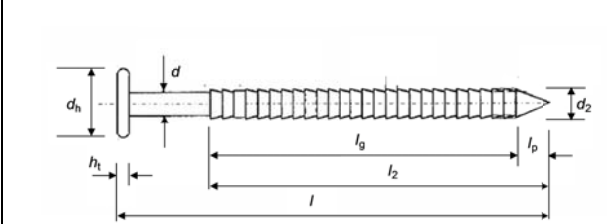
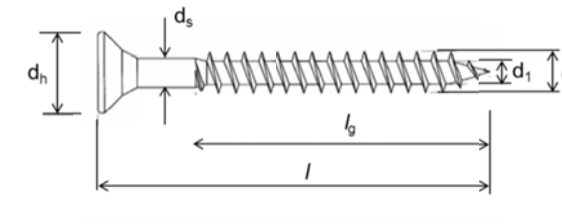
Essential characteristic	Table 8a - Specifications mechanical fixings [a]		Harmonised technical specification
	Ring-shank nail for Lines ² 10 mm fixing	Flat-top screw 3.5 x 30 mm for Lines ² 10 mm fixing	
BR4 – Safety in use	Stainless steel in accordance with EN 10088 Material number 1.4401 or 1.4578	Stainless steel in accordance with EN 10088 Material number 1.4301, 1.4401 or 1.4578	ETA-13/0204 issued 2015-11-10 Table 14 and Table 15 EN 14592:2008 +A1:2012
	 <p>Minimum required dimensions (mm) $d = 3.5 - 3.2$ $0.6 \cdot d \leq d_1 \leq 0.9 \cdot d$ $l \geq 29.0$ $l_g \geq 22.5$ $d_h = 7.0 - 6.6$ $d_s = 2.6 - 2.3$</p>		
	[a] for preservative treatment subframes see Table 9		

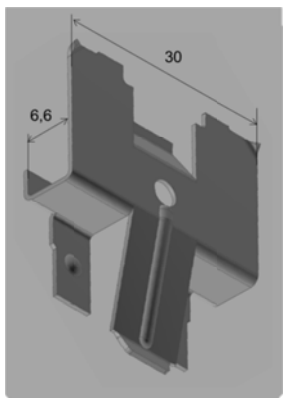
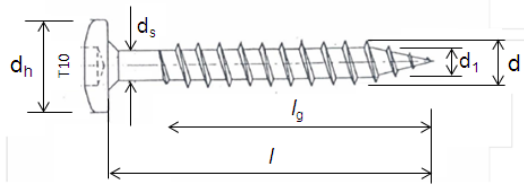
Essential characteristic	Table 8b - Specifications mechanical fixings Fixing clip Lines ² 8 mm and Torx T10 screws 3,5 x 25 mm for clip fixing		Harmonised technical specification	
				ETA-13/0204 issued 2015-11-10 Table 16
BR4 – Safety in use	Stainless steel in accordance with EN 10088 Material number 1.4301		EN 14592:2008 +A1:2012	
	Material number 1.4310 Material thickness : 0.6 mm	d = 3.5 – 3.2 mm d ₁ = 2.3 ± 0.15 mm d _s = 2.30 ± 0.15 mm		l = 25.00 ± 1.15 mm l _g ≥ 21.25 mm d _h = 7.0 - 0.4 mm
	[a] for preservative treatment subframes see Table 9 Remark: In the case a ROCKPANEL strip is used between the back of the clip and the front of the batten, the length of the screw shall be increased with the thickness of the strip.			

Essential characteristic	Table 9 – Performance Subframes		Harmonised technical specification
	Appropriate preservative treatment of subframes		
BR4 – Safety in use	Use the appropriate part of EN 335 to identify the "use class" of a given service environment and geographical location. Table 1 in EN 335 will assist in determining the biological agents that can attack timber in certain situations. The user can then consider the type and duration of performance required, select an appropriate level of durability and ensure that the timber or wood-based product specified has either, as a natural (see EN 350-2) or an acquired characteristic durability as the result of appropriate preservative treatment (see EN 351-1).		ETA-13/0204 issued 2015-11-10

Essential characteristic	Table 10 – Performance Impact resistance Lines² - 8 and 10 mm			Harmonised technical specification
	Impactor	Energy	Category	
BR4 – Safety in use	Hard body	Steel ball 0.5 kg	1 J	IV
		Steel ball 3.0 kg	3 J	III, II, I
				ETA-13/0204 issued 2015-11-10

Essential characteristic	Table 11 – Performance dimensional stability		Harmonised technical specification
BR4 – Safety in use	Cumulative dimensional change [a]		0.085%
	Coefficient of thermal expansion (10 ⁻⁶ K ⁻¹)		10.5
	Coefficient of moisture expansion 42% RH difference after 4 days (mm/m)		0.302
[a] As a consequence the minimum joint width shall be 3 mm, preferably 5 mm.			

Essential characteristic	Table 12 – Resistance to hygro-thermal cycles and Xenon Arc exposure		Harmonised technical specification	
				Performance
Aspects of durability and serviceability	Resistance to Hygrothermal cycles		Pass	
	Resistance to Xenon Arc exposure EOTA TR010 climate class S (Technical Report 010)	Finish 'Colours/Rockclad'	ISO 105 A02: 3-4 or better	
	5000 hours artificial weathering			
				ETA-13/0204 issued 2015-11-10

8. *The performance of the product identified above is in conformity with the set of declared performance/s. This declaration of performance is issued, in accordance with Regulation (EU) No 305/2011, under the sole responsibility of the manufacturer identified above.*

*Signed for and on behalf of the
manufacturer by:*

ROCKWOOL B.V.
W.J.E. Dumoulin
Technical Director Operations DE-NL



At Roermond,
The Netherlands

on 4th February 2016

DOP in accordance with Commission Delegated Regulation (EU) No 574/2014 of 21 February 2014 amending Annex III to Regulation (EU) No 305/2011 of the European Parliament and of the Council on the model to be used for drawing up a declaration of performance on construction products, <http://eur-lex.europa.eu/legal-content/EN/TXT/?uri=celex%3A32014R0574>, OJ L 159, 28.5.2014, p. 41-46